

TAXIMETER P6

**8. POWER CONNECTOR SEALING**

**8.1 P6F Power connecting sealing**

POWER CONNECTOR SEALING	PROCEDURE	DESCRIPTION
		 <p>Seal Screw Screw Base Seal Cover</p>
	STEP 1	 <p>Power Connector</p>
	STEP 2	 <p>Power Cable</p>
	STEP 3	 <p>Sealing Cover</p>
	STEP 4	 <p>Sealing Screw &amp; Screw Base</p>

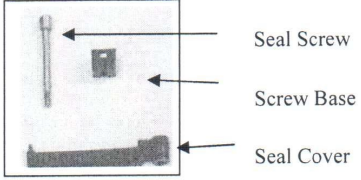
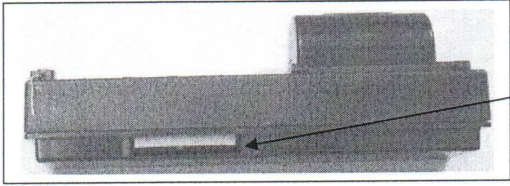
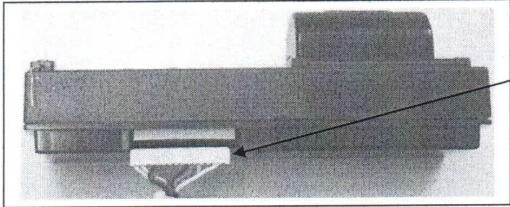
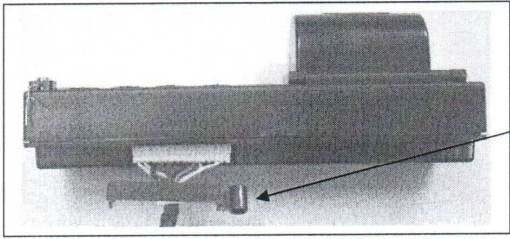
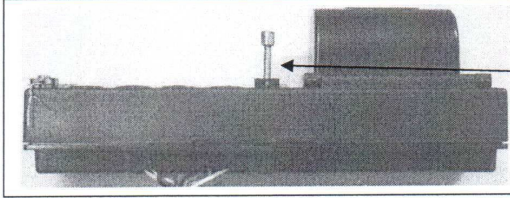
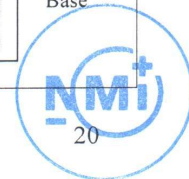

TAXIMETER P6

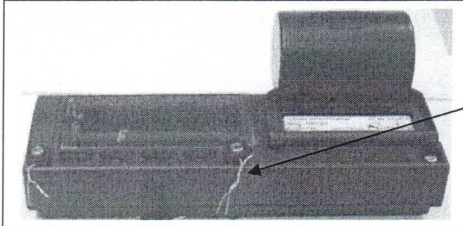
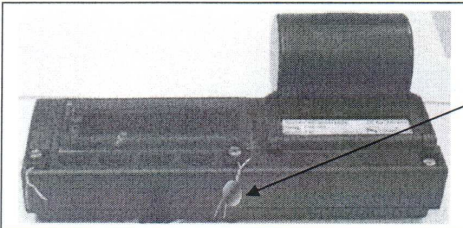
	STEP 5		Metallic Cord through hole in Sealing Screw and Screw Base
	STEP 6		Cord secured with Lead Seal. Power Cable is sealed.

8.2 P6S Power connecting sealing

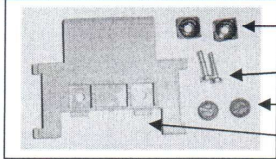
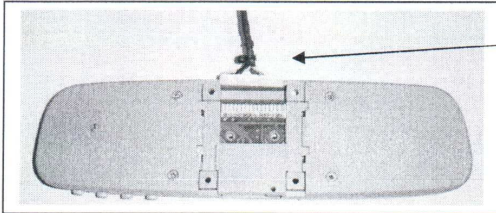
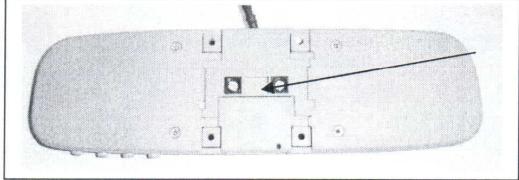
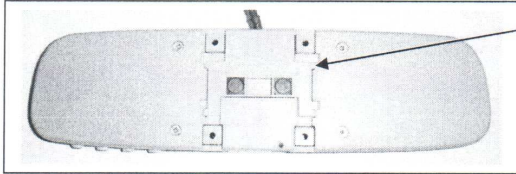
POWER SEALING	PROCEDURE	DESCRIPTION
		 <p>Screw Base Seal Screw Seal Cover Power Cover</p>
	STEP 1	 <p>Power Cable</p>
	STEP 2	 <p>Sealing Screw, screw base, power cover</p>
	STEP 3	 <p>Sealing covers have been placed</p>

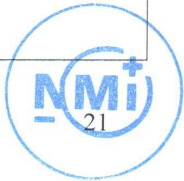

TAXIMETER P6

**10. PROGRAMMING PORT SEALING**

**10.1 P6F PROGRAMMING PORT SEALING**

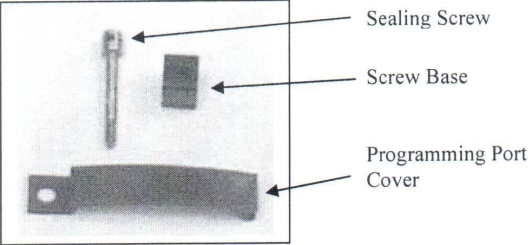
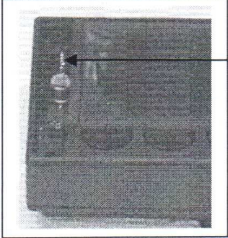
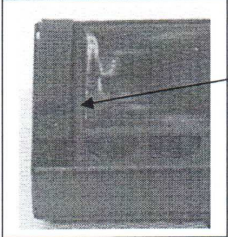
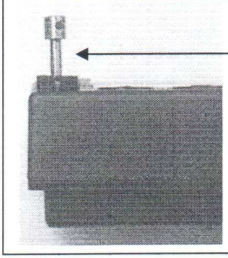
PROGRAMMING PORT SEALING	PROCEDURE	DESCRIPTION
		 <p>Sealing Screw</p> <p>Screw Base</p> <p>Programming Port Cover</p>
	STEP 1	 <p>Programming Port</p>
	STEP 2	 <p>Installation of Programming Port Cover</p>
	STEP 3	 <p>Sealing Screw &amp; Screw Base</p>

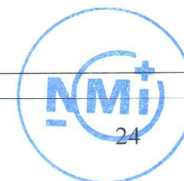

TAXIMETER P6

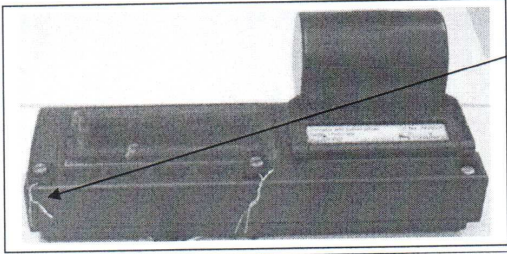
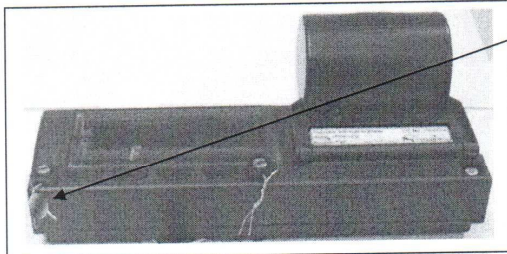
	<p>STEP 4</p>		<p>Metallic Cord through hole in Sealing Screw and Screw Base.</p>
	<p>STEP 5</p>		<p>Cord secured with Lead Seal. Programming Port is sealed.</p>

10.2 P6S PROGRAMMING PORT SEALING

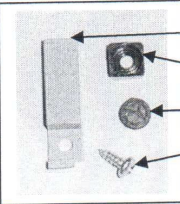
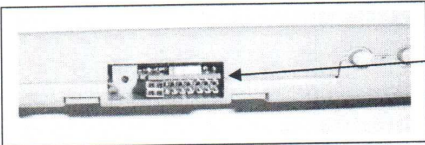
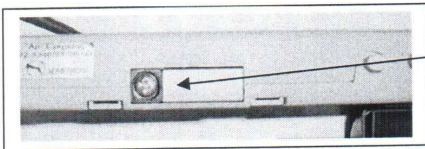
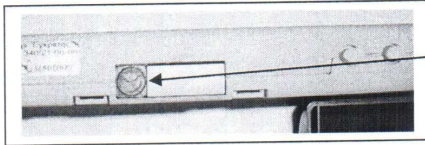
PROGRAMMING PORT SEALING	PROCEDURE	DESCRIPTION
		 <p>Programming Port Cover Screw Base Sealing cover Sealing Screw</p>
	<p>STEP 1</p>	 <p>Programming Port</p>
	<p>STEP 2</p>	 <p>Programming Port Cover Screw Base Sealing Screw have been placed</p>
	<p>STEP 3</p>	 <p>Sealing covers have been placed</p>

